

ASSEMBLY INSTRUCTION
CRAIG KING SINGLE BED BASE
85143

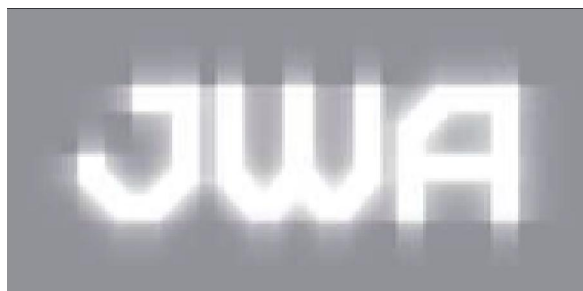
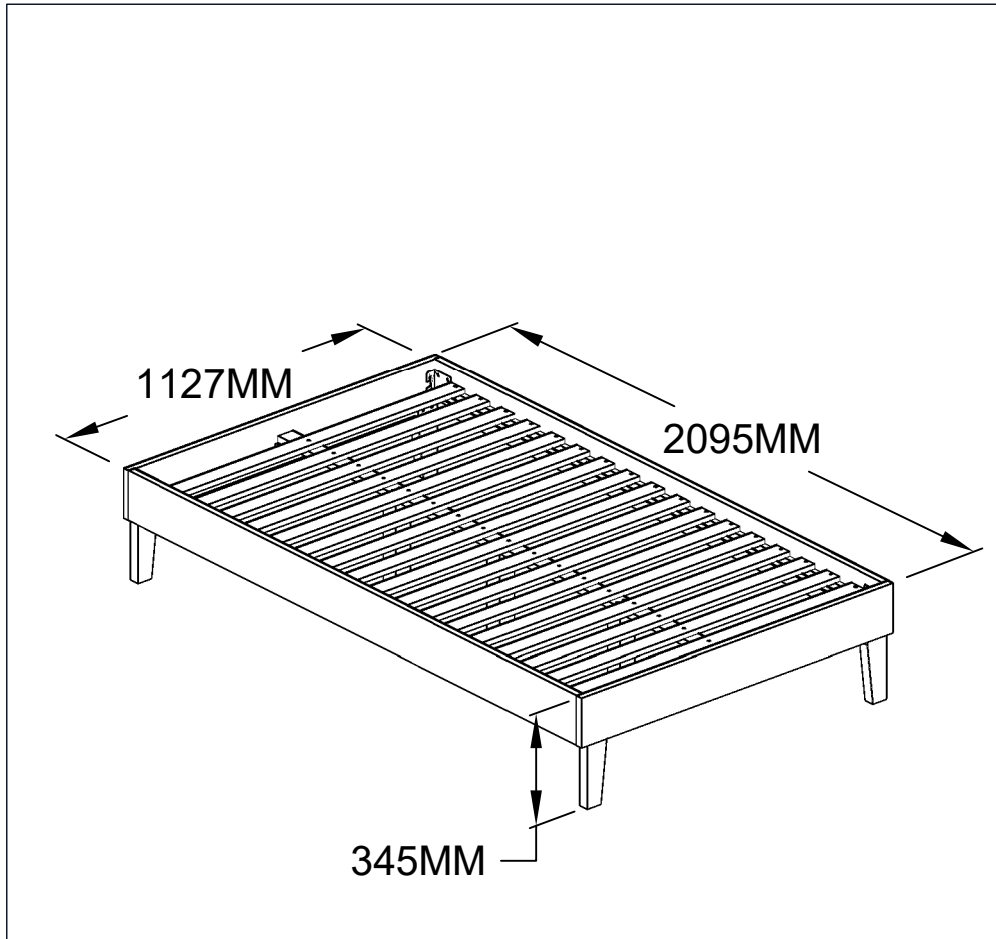

Imported by JWA Furniture Pty Ltd, Qld, Brisbane Australia.
For any assistance with assembly or for missing parts please refer to your receipt

PRE-ASSEMBLY PREPARATION

Before you start:



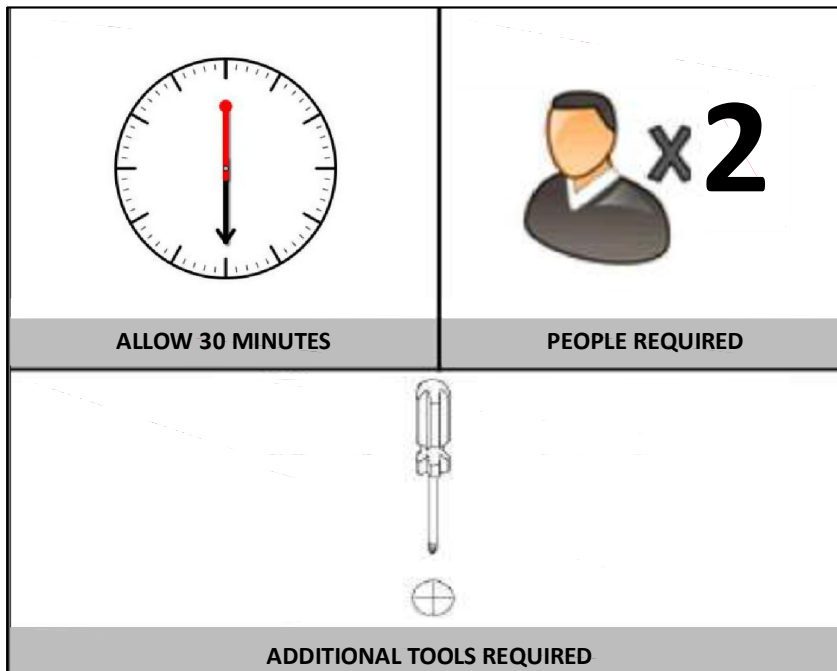

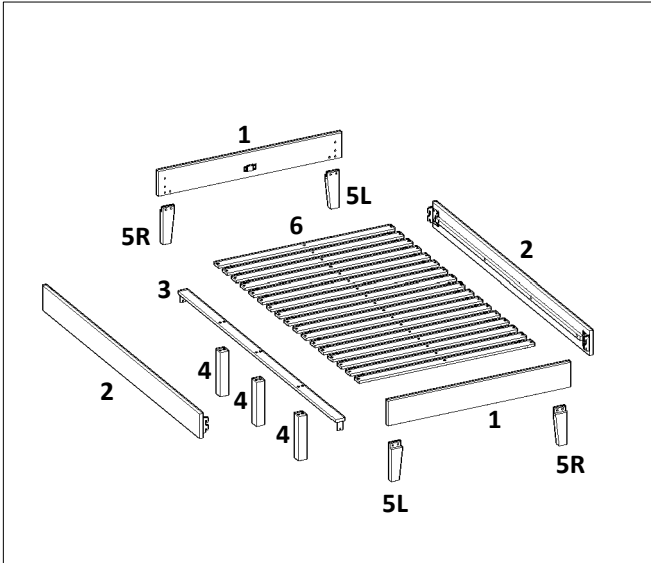

1. Choose a clean, level, spacious assembly area. Avoid hard surfaces that may damage the product
2. Take care when lifting. Product should be assembled as near as possible to the point of use
3. Ensure that you have all required contents for complete assembly
4. Always read the assembly instructions carefully before beginning assembly.
5. Keep all hardware parts and packaging out of reach of small children.
6. Do not over tighten the screws and bolts as this may damage the threads



PARTS LIST

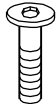

| | |
|---|-----------------------|
| 1 | HEADBOARD & FOOTBOARD |
| 2 | SIDE RAIL |
| 3 | CENTER RAIL |
| 4 | CENTER SUPPORT LEG |
| 5 | BED LEG (L+R) |
| 6 | SLATS |

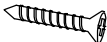
| | | |
|---|---|--|
| <p>A Allen Key M4</p>  <p>1xA</p> | <p>B Allen Key M5</p>  <p>1xB</p> | <p>C JCBB M8 x 30mm</p>  <p>8xC</p> |
| <p>D JCBC M6 x 40mm</p>  <p>6xD</p> | <p>E JCBC M6 x 25mm</p>  <p>6xE</p> | <p>F M8 Spring Washer</p>  <p>8xF</p> |
| <p>G M8 Flat Washer</p>  <p>8xG</p> | <p>H Wood Screw M3.5 x 16mm</p>  <p>2xH</p> | <p>I Wood Screw M4 x 25mm</p>  <p>45xI</p> |

STEP 1 : Attach (3L) and (3R) to (1) With (C),(F) and (G) Using a Allen Key M5 (B) as shown. (Arrows sticker points upward)

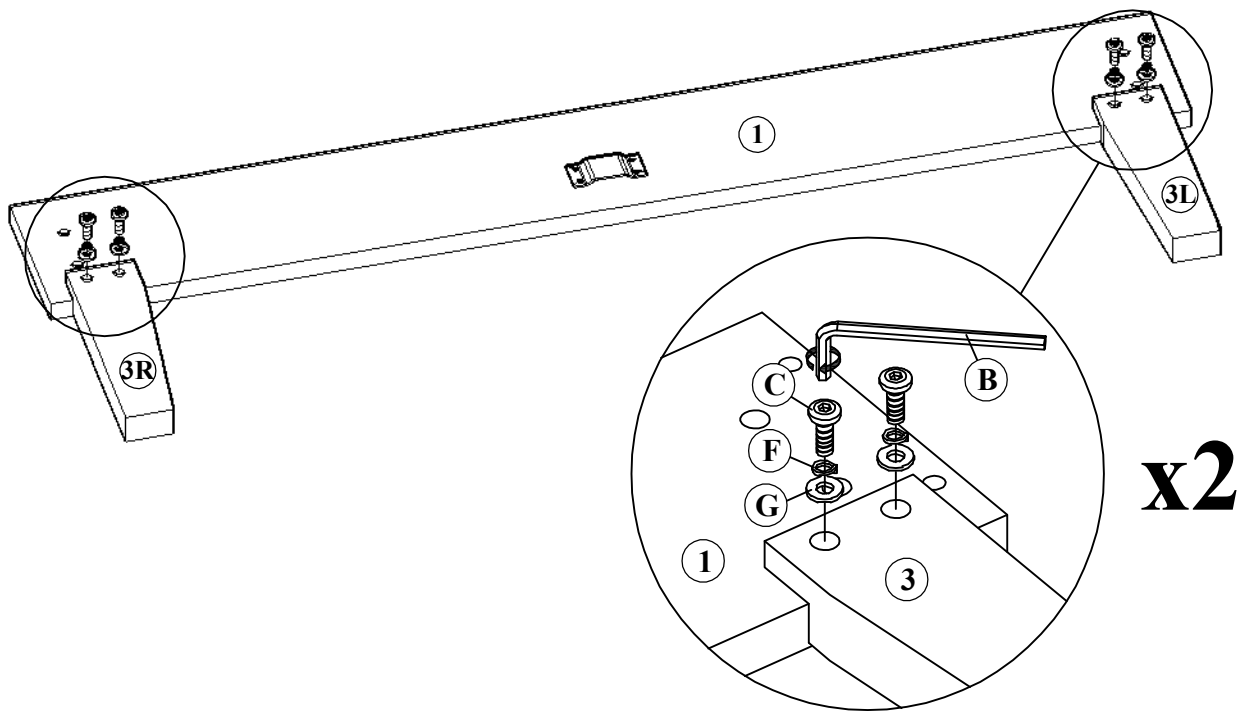

STEP 2 : Attach to Assembled Headboard and Assembled Footboard with the pre-attached bolt using a Allen Key M5 (B) as shown.

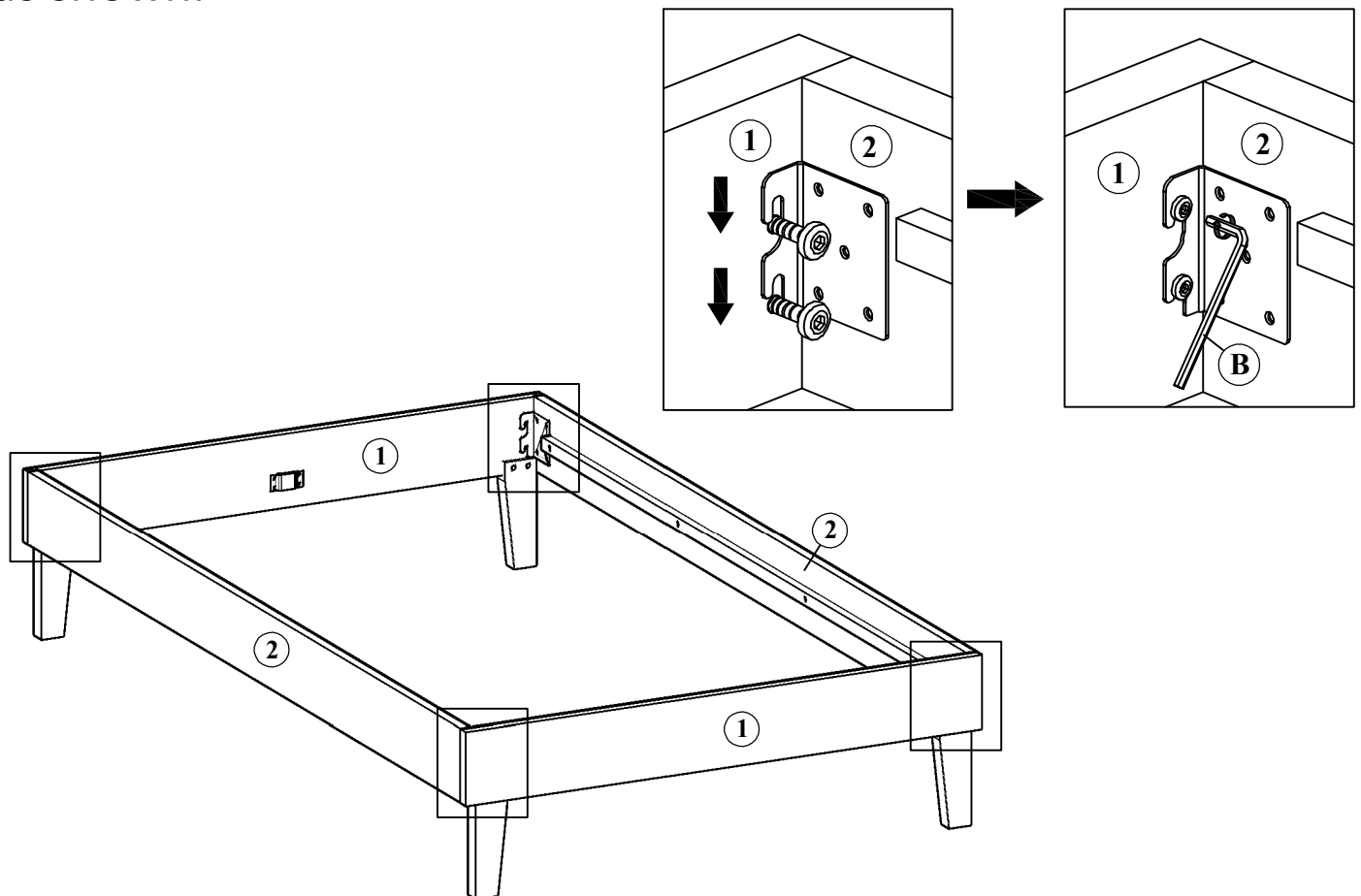

STEP 3 : Attach (3) to (4) with (D) Using a Allen Key M4 (A) as shown.

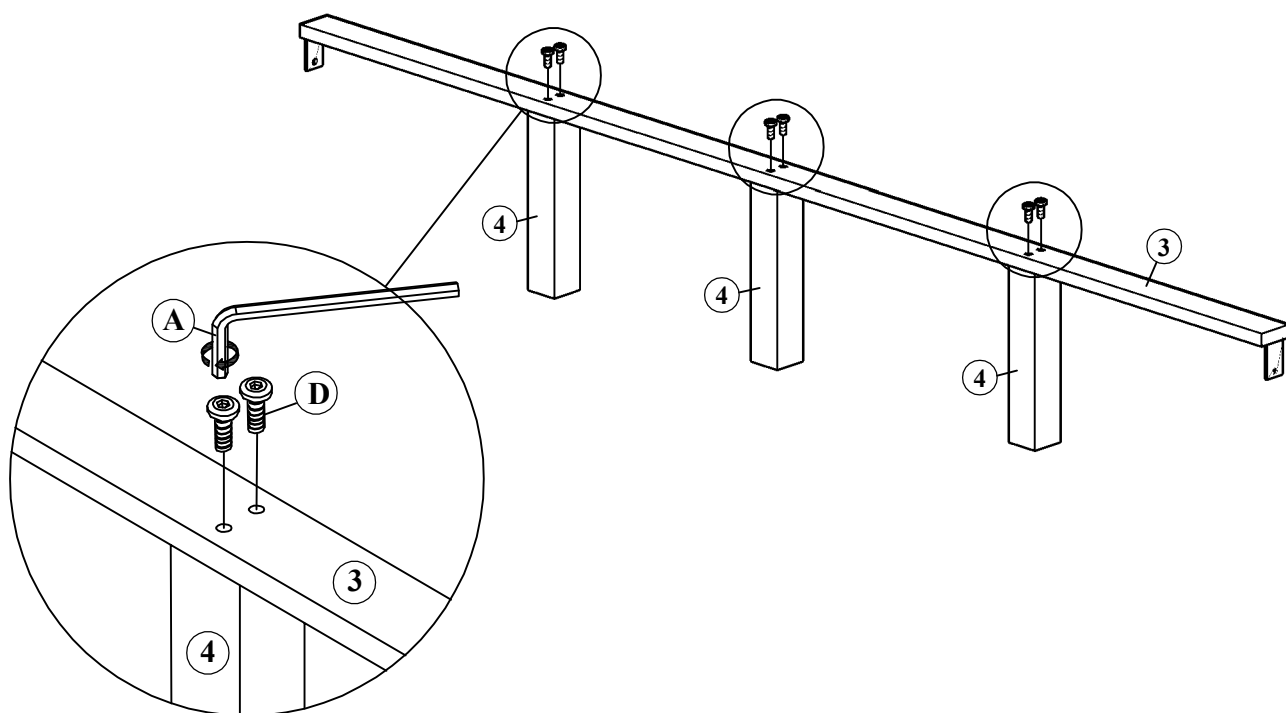

STEP 4 : Attach Assembled Center Support to Assembled Bed with (H) using a Screwdriver as shown.

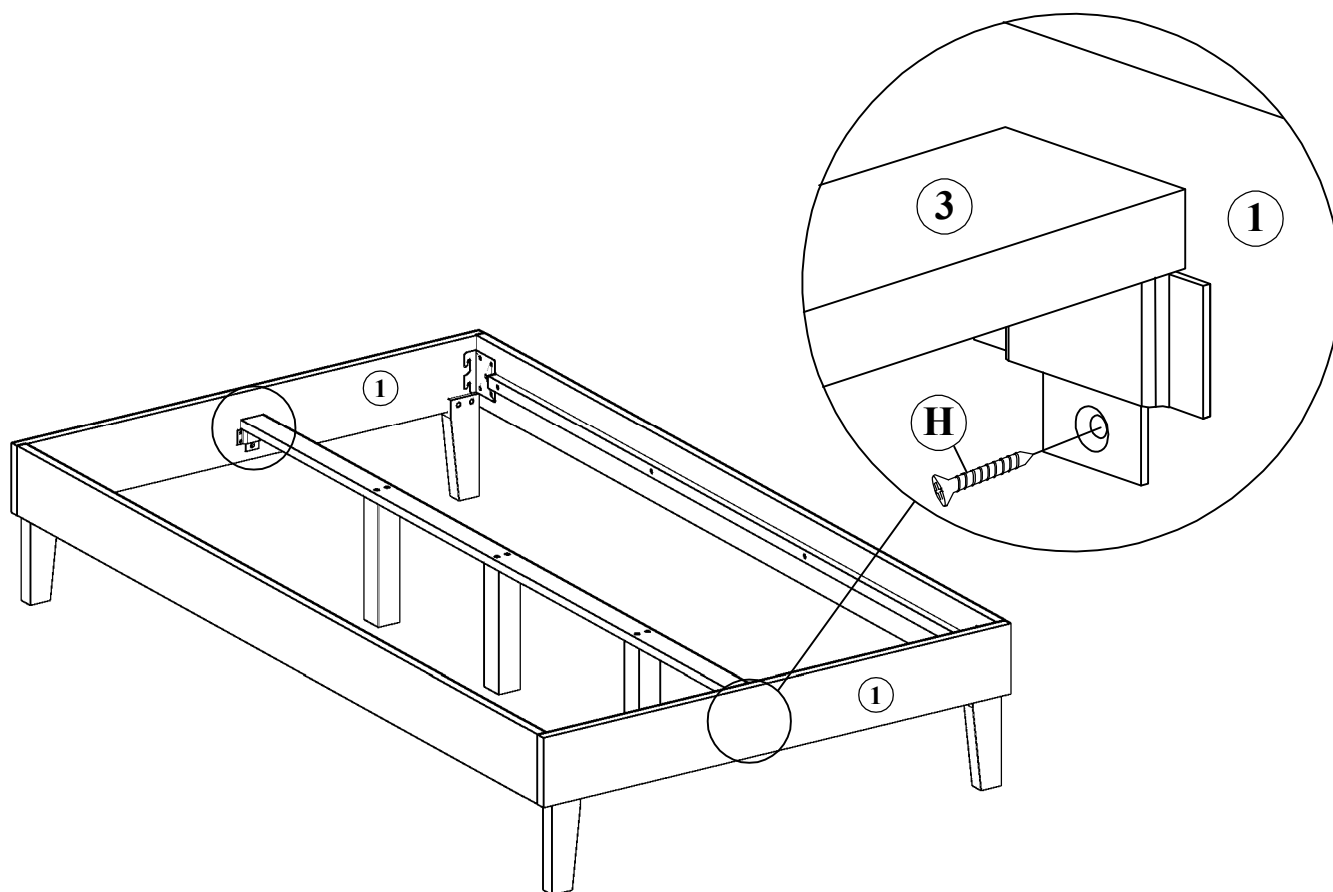

STEP 5 : Attach Assembled Bed Slats (6) to Assembled Bed Frame with (E) Using a Allen Key M4 (A) as shown.

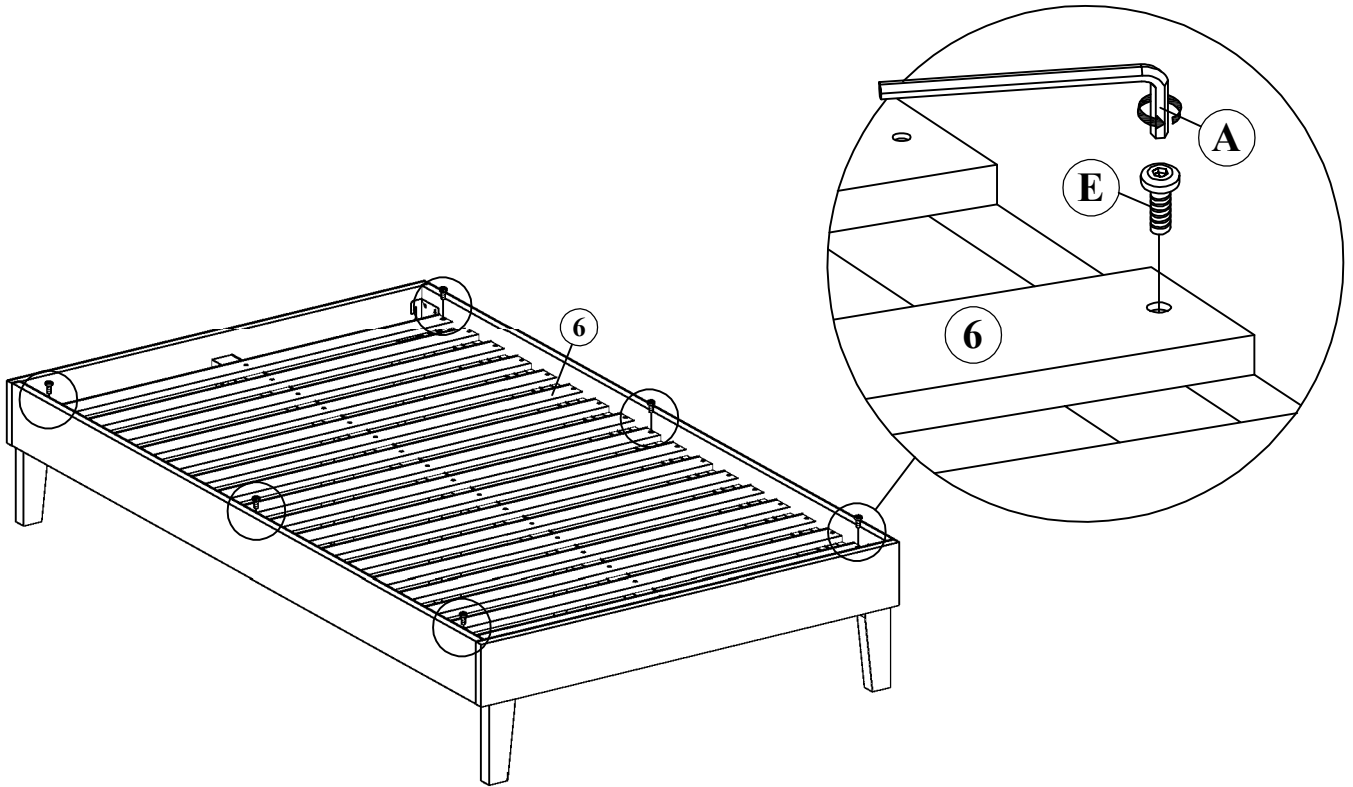

STEP 6 : Attach Assembled Bed Slats to Assembled Bed Frame with (I) using a Screwdriver as shown.

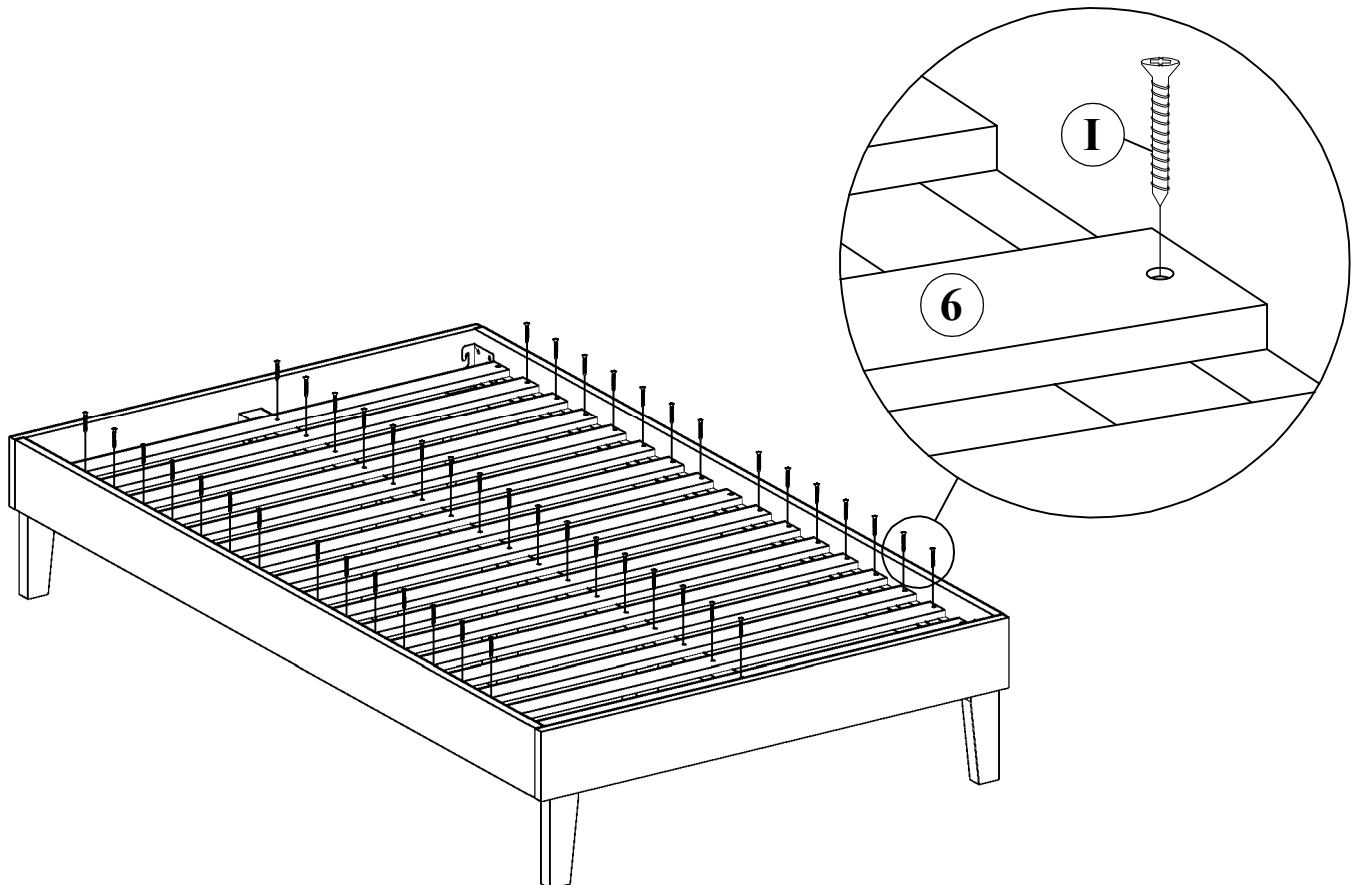

ASSEMBLY IS COMPLETE

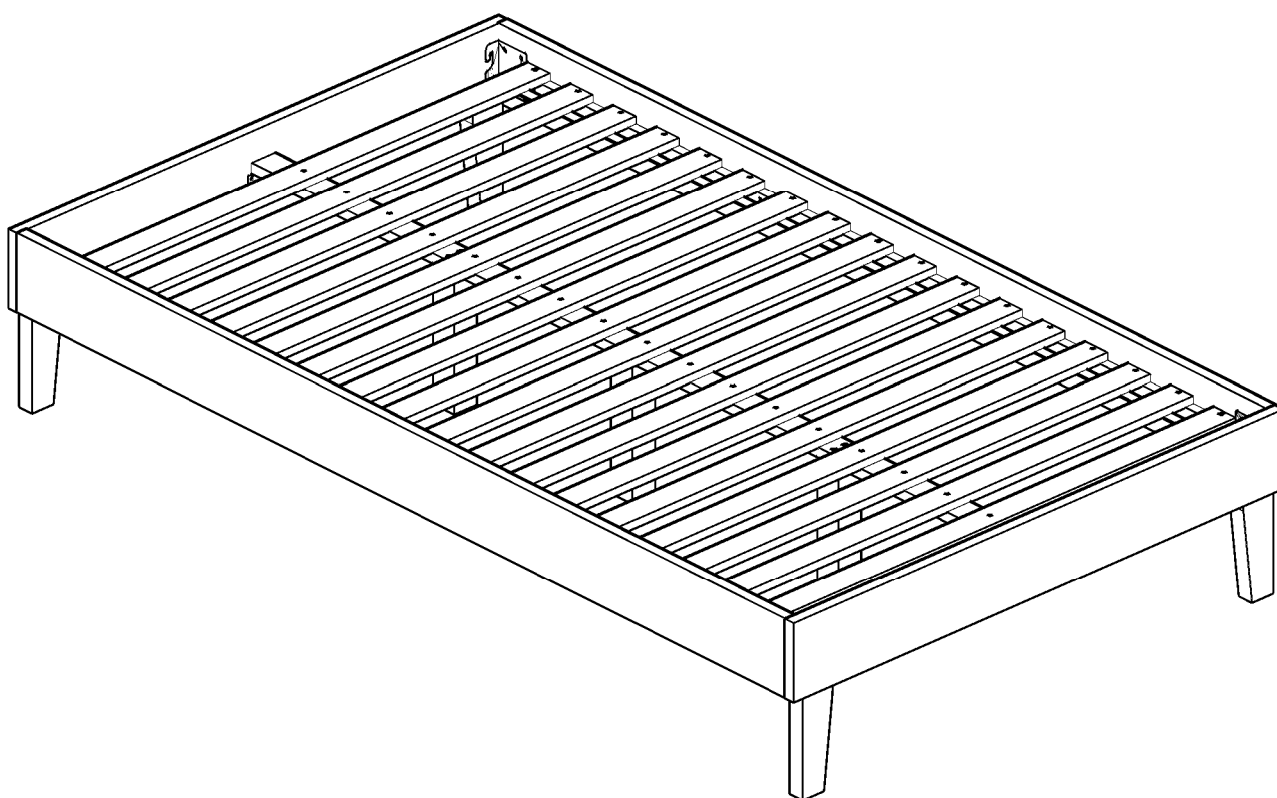

CAUTION:

ALWAYS LIFT YOUR BED WHEN MOVING/RELOCATING - DO NOT DRAG.
DRAGGING CAN CAUSE THE CENTRE SUPPORT LEGS TO BEND/BREAK

PRODUCT CARE:

REGULAR CARE:

As our timber is supplied from sustainable forests there will be natural variations in surface texture and grain like knots, mineral streaks and sap runs that may affect the finish. These differences in character are not defects, but distinctions that make each piece of furniture unique

Our furniture is built to last. Following these steps for basic care should protect your investment for years to come

- **Dust frequently with a clean damp lint-free cloth. This will help remove abrasive build up which can damage a finish over time**
- **Do not place hot objects on any furniture surface. Always use a hot plate or placemat. Laminate and lacquer finishes on table tops provide added scratch and heat resistance to our furniture, but they can still be damaged without proper care**
- **Avoid exposing your furniture to strong sunlight, heat outlet, open windows or dampness. Prolonged exposure to direct sunlight can fade the finish of your furniture, while extreme temperature and humidity changes can cause cracking or splitting**
- **Do not expose your furniture to any liquids. Never allow water to sit on your furniture. Alcohol, nail polish and perfume are also dangerous as they will dissolve the lacquer finish on contact and may require professional repairs**
- **Do not allow plastic to come in direct contact with your furniture. Chemicals in the plastic of placemats etc. may soften and mark the finish if left in contact with the furniture for a period of time**